

Observational Study

Hospital-acquired insomnia scale: A validity and reliability study

Bahar Çiftçi, Güzel Nur Yıldız, Özgür Yıldız

Specialty type: Nursing**Provenance and peer review:**

Invited article; Externally peer reviewed.

Peer-review model: Single blind**Peer-review report's scientific quality classification**

Grade A (Excellent): A

Grade B (Very good): B

Grade C (Good): 0

Grade D (Fair): 0

Grade E (Poor): 0

P-Reviewer: Bharara T, India; Taheri S, Iran**Received:** December 27, 2022**Peer-review started:** December 27, 2022**First decision:** January 31, 2023**Revised:** February 4, 2023**Accepted:** March 14, 2023**Article in press:** March 14, 2023**Published online:** March 19, 2023**Bahar Çiftçi**, Department of Fundamental of Nursing, Atateknokent Atatürk University, Erzurum 25000, Turkey**Güzel Nur Yıldız**, Department of Dialysis, Muş Alparaslan University, Muş 49000, Turkey**Özgür Yıldız**, Department of Nursing, Muş Alparaslan University, Muş 49000, Turkey**Corresponding author:** Bahar Çiftçi, PhD, Assistant Professor, Department of Fundamental of Nursing, Atateknokent Atatürk University, Erzurum/Yakutiye, Erzurum 25000, Turkey. bahar.ciftci@atauni.edu.tr**Abstract****BACKGROUND**

Sleep breathing, one of the basic human needs, is a physiological need that affects cardiac functions, body temperature, daily vitality, muscle tone, hormone secretion, blood pressure, and many more. In the international literature, studies reported that patients have had sleep problems in the hospital since the 1990s, but no measurement tool has been developed to determine the causes of hospital-acquired insomnia in individuals. These findings suggest that sleep remains in the background compared to activities such as nutrition and breathing. Although patients generally experience hospital-acquired sleep problems, there is no measurement tool to determine hospital-acquired sleep problems. These features show the originality of the research.

AIM

To develop a measurement tool to determine the sleep problems experienced by patients in the hospital.

METHODS

A personal information form, hospital-acquired insomnia scale (HAIS), and insomnia severity index (ISI) were used to collect research data. The study population consisted of patients hospitalized in the internal and surgical clinics of a research hospital in Turkey between December 2021 and March 2022. The sample consisted of 64 patients in the pilot application stage and 223 patients in the main application stage. Exploratory factor analysis and confirmatory factor analysis (CFA) analyses were performed using the SPSS 20 package program and the analysis of moment structure (AMOS) package program. Equivalent forms method used.

RESULTS

The HAIS consisted of 18 items and 5 subscales. The Cronbach alpha values of the subscales ranged between 0.672 and 0.842 and the Cronbach alpha value of the overall scale was 0.783. The scale explained 58.269% of the total variance. The items that constitute the factors were examined in terms of content integrity and named as physical environmental, psychological, safety, socioeconomic, and nutritional factors. CFA analysis of the 5-factor structure was performed in the AMOS package program. The fit indices of the obtained structure were examined. It was determined that the values obtained from the fit indices were sufficient. A significant correlation was determined between the HAIS and the ISI, which was used for the equivalent form method.

CONCLUSION

The HAIS is a valid and reliable measurement tool for determining patients' level of hospital-acquired insomnia. It is recommended to use this measurement tool to determine the insomnia problems of patients and to adapt it in other countries.

Key Words: Insomnia; Sleeplessness; Sleep disorder; Scale development; Hospital; Hospital housekeeping

©The Author(s) 2023. Published by Baishideng Publishing Group Inc. All rights reserved.

Core Tip: Sleep, which is one of the basic human needs, is a physiological need that affects heart functions, hormone secretion, mood, psychological state and many more. Although there are studies in the international literature reporting that patients have sleep problems in the hospital since the 1990s, a measurement tool has not been developed to determine the causes of hospital-acquired insomnia in individuals. Determination of hospital-acquired insomnia causes of individuals; It will provide many benefits such as increasing the quality of care, improving mood, reducing stress levels, increasing the effectiveness of treatment, and increasing psychological resilience. In this research, a measurement tool was developed to identify the causes of hospital-acquired insomnia and to identify the causes of insomnia in hospitals or inpatient health institutions by focusing on the vital sleep activity. A measurement tool consisting of 18 items and 5 factors was developed. In addition, the literature on the factors that cause hospital-acquired insomnia was reviewed and some recommendations were made.

Citation: Çiftçi B, Yıldız GN, Yıldız Ö. Hospital-acquired insomnia scale: A validity and reliability study. *World J Psychiatry* 2023; 13(3): 113-125

URL: <https://www.wjgnet.com/2220-3206/full/v13/i3/113.htm>

DOI: <https://dx.doi.org/10.5498/wjp.v13.i3.113>

INTRODUCTION

Sleep breathing, one of the basic human needs, is a physiological need that affects cardiac functions, body temperature, daily vitality, muscle tone, hormone secretion, blood pressure, and many more. With these properties, sleep is the basic need for human survival[1-3]. Some conditions such as pregnancy, stress, menopause, physical diseases, and hospitalization increase the need for sleep[1,4]. Sleep plays an important role in maintaining health and recovering diseases[1,3]. Moreover, sleep is a need that people are most vulnerable to deprivation and must inevitably be replaced[2].

Insomnia can be defined as difficulty falling asleep, maintaining or ending sleep, and situations in which individuals do not feel rested or ready for the new day because they do not sleep enough or for a sufficient time[1,2]. Insomnia can occur independently or due to other problems. Temporary insomnia, which may arise from reasons such as stress, is a common problem, including in hospitals. Studies show that 33% to 69% of patients experience sleep deprivation in the hospital[5-7].

Insomnia is a common patient complaint during hospitalization[8-12]. While in the hospital, patients may experience sleep problems due to many reasons such as hospitalization, not getting used to the bed, being away from the family, a foreign environment, disease anxiety, surgical interventions, sound, light, noise, inability to meet the needs of daily living, and deterioration in body image[13,14]. In addition, it is stated that some factors such as the high number of patients in the room, room temperature, implementations made at sleep time, and the obligatory sleeping positions affect sleep patterns in the hospital[15]. It is stated that the reasons such as the stuffiness of the room, smell, reasons arising from the bedding, inconvenience of the bed and the pillow, pain, lack of information, drugs, tubes such as drains-catheters, hunger-fullness also cause sleep problems among hospitalized patients [16]. In another study, it was stated that in intensive care units, sleep is affected by factors originating from intensive care (noise, patient care, and treatment practices) and disease-related factors (pain,

anxiety, disease severity, drugs, mechanical ventilation)[17].

Individuals resort to medication since insomnia creates stress and anxiety in individuals. However, in this process, it will be a more effective method to determine the cause of insomnia, take precautions, eliminate the cause, make necessary arrangements for sleep, plan the nursing care accordingly, and use medication as a last resort[2,18,19]. The ability of a nurse to solve this problem is associated with his/her ability to evaluate sleep and the appropriateness of the measurement tools used.

According to the literature, scales such as the Epworth sleepiness scale[20], Pittsburg sleep quality index[21], DSM-5 sleep-wake disorders module[22], Richard-Campbell sleep questionnaire[23], postpartum sleep quality scale[24], sleep quality scale[25], Jenkins sleep scale[26], sleep hygiene index [27], sleep assessment scale for children with cancer[28] are used to determine sleep-related problems in our country. In addition, the form of factors affecting sleep[29] is used to evaluate sleep in terms of quantity and quality. As can be understood from the names of the scales, there is no measurement tool to measure the causes of hospital-acquired insomnia. In the international literature, studies reported that patients have had sleep problems in the hospital since the 1990s, but no measurement tool has been developed to determine the causes of hospital-acquired insomnia in individuals. These findings suggest that sleep remains in the background compared to activities such as nutrition and breathing. This research focuses on the activity of sleep, which is vital and aimed to develop a measurement tool to reveal the causes of hospital-acquired insomnia and determine the causes of insomnia in hospitals or inpatient health institutions. In addition, literature on the factors that cause hospital-acquired insomnia was reviewed and some recommendations were made. These features show the originality of the research.

MATERIALS AND METHODS

Research type

The research was designed as a methodological study.

Research place and time

The study was conducted with patients hospitalized in surgical and internal medicine clinics in a research hospital in Turkey between December 2021 and March 2022.

Research population and sample

The population of the study consisted of patients hospitalized in Turkey. During the pilot application of the study, 64 patients were reached. It is stated that the sample size should be at least 5 times the number of scale items (10 times if possible) in scale adaptation studies[30]. The main application stage started with 42 items. For this reason, it was predicted that the sample size should have been at least 210 or 420. Therefore, 223 patients were reached during the main application stage. The data were filled in using the face-to-face interview method. It took 20-30 min to fill in the data of each patient. The study was completed with a total of 287 patients.

Inclusion criteria of research

(1) Not having any sleep problems before hospitalization; and (2) Being hospitalized for at least three days.

Data collection tools

The data were collected using a personal information form and the hospital-acquired insomnia scale (HAIS)-draft form.

Personal information form: This form consists of questions about gender, age, education level, social security, and previous hospitalization of the participants.

Insomnia severity index: The index was developed by Bastien *et al*[31] in 2001 and was validated in Turkish by Boysan *et al*[32] in 2010. The 7-item index was developed in a 5-point Likert type in order to measure the degree of insomnia of individuals. Items are scored between 0-4; the lowest score obtainable from the scale is 0 and the highest score is 28. In scoring, a score of 0-7 indicates clinically insignificant insomnia; 8-14 indicates insomnia lower threshold; 15-21 indicates clinical insomnia (moderately severe); 22-28 indicates clinical insomnia (insomnia) (severe). Insomnia severity index (ISI) was used to determine the concurrent validity of the scale. Concurrent validity is the comparison of the findings obtained from a measurement tool that is desired to be developed with a scale, whose validity and reliability has been proven, on a similar subject. A correlation is expected between the data obtained from both measurement tools[33].

HAIS: First stage: The relevant literature was examined in depth. Interviews were held with 2 patients, 2 patient relatives, and 4 nurses about the causes of hospital-acquired insomnia. After the literature

review and interviews, a conceptual infrastructure on the subject was created. An item pool of 150 items considered suitable for the scale was prepared. The item pool was reviewed 4 times and some items were eliminated. The item pool was finalized with 66 items for expert opinion.

Second stage: The item pool consisting of 66 items was presented to 11 experts (2 Turkish language experts, 9 field experts) and the content validity was evaluated. The items in the scale were revised in line with expert opinions. Then, the suitability of the scale items was evaluated, the Turkish language validity was established, and the revisions were completed. 10 items were removed from the scale. The scale was finalized for the pilot application with 56 items. The Cronbach alpha value of the data of 56 items was determined as 0.882. In the pilot application stage, 14 items (i4, i6, i9, i12, i14, i19, i22, i26, i29, i30, i32, i35, i36, i43) with an item correlation value of less than 0.20 were removed from the item pool. The Cronbach alpha value was determined to be 0.913 with 42 items. Main application stage started with 42 items.

Third stage: Validity and reliability analysis of the HAIS was performed. The sample of the study consisted of 223 patients. In the analyses, it was determined that the scale is a valid and reliable measurement tool consisting of 18 items and 5 subscales. The scale was developed as a 5-point Likert scale (1: Strongly disagree - 5: Strongly agree). Scoring for the subscales and the overall scale was based on the item score average. The lowest score obtainable from the scale and its subscales is 1 and the highest score is 5. There is no reverse item on the scale. As the scale score increases, hospital-acquired insomnia increases. There is no cut-off point in the scale. The Cronbach alpha value for the overall scale was determined to be 0.783.

Pilot application

In scale adaptation studies, it is necessary to reach a sample size of more than 50; the internal consistency of the scale should be 0.70 and above; it should be checked whether the item-total correlation value is below 0.30[34]. In this study, the pilot application was carried out with 64 patients. In the pilot application stage, 14 items with an item correlation value below 0.20 were removed from the item pool. The Cronbach alpha value was determined to be 0.913 with 42 items and the main application stage was initiated.

Main application

The patients were visited in their rooms and their informed consent was obtained. After their consent was taken, the data of the study were collected by the face-to-face method. The scale items were asked to the patients one by one by the researcher (BÇ) and their answers were marked. At this stage, the HAIS and the ISI, which is thought to be a parallel form, were used. In the main application, 223 patients were reached. At this stage, validity and reliability analyses, two criteria that a scale should have, were performed[35].

Statistical analysis

SPSS 20 package program and analysis of moment structure (AMOS) 20 package program" were used for data analysis. Frequency and percentage were used to indicate the sociodemographic characteristics of the patients. Exploratory factor analysis (EFA) and confirmatory factor analysis (CFA) were used to ensure scale validity. In the EFA, item score averages and standard deviations, Kaiser-Meyer-Olkin (KMO), Bartlett's test of sphericity, item-total correlation value was used. Scree plots chart and eigenvalue were used to determine the factor structures of the scale[34,36,37].

KMO and Bartlett's sphericity tests were performed to check the suitability of the sample size and the suitability of the data set for analysis. The fact that the KMO test was greater than 0.60 and the *P* value of the Bartlett's sphericity test was significant showed the adequacy of the sample and the suitability of the data set[34,38,39].

EFA was performed to ensure construct validity. During the EFA, there should be no overlapping items. In addition, the item eigenvalue of the scale items should be at least 1 and the item load should be at least 0.30[34,40]. Varimax rotation, which is a vertical rotation method preferred in scale development studies, was used to ensure construct validity[34,36]. The presence of multicollinearity problem was tested with linear regression [variance inflation factors (VIF) < 10, C-index (CI) < 30, tolerance > 10][38]. If an item has a loading value of more than 0.32 in more than one dimension and the difference between factor loadings in these dimensions is less than 0.10, these items were accepted as overlapping items[34].

In CFA, fit indices and path diagram were used. The Cronbach alpha value of the items, factors and total scale was used to determine the reliability level of the scale. In addition, split half analysis was performed. Retest method was used to determine the invariance of the scale against time. The following criteria were taken as basis: a minimum KMO value of 0.60, a Bartlett's test of sphericity *P* value being significant, an eigenvalue of at least 1, a Cronbach alpha value of at least 0.7 for factors and the scale, a split half Cronbach alpha value of at least 0.7. The values suggested by Bae *et al*[41], Woo *et al*[42] were taken into account in the fit indices [χ^2 /SD value, goodness of fit index (GFI), adjusted GFI, comparative fit index, root mean square error of approximation, standardized root mean square residual fit indices] [41,42].

In the analyzes related to reliability, a Cronbach alpha value of 0.70 and above was taken as the basis [43-45].

Ethical aspects and permissions

Ethics committee approval dated 16.08.2021 and numbered 20028 was obtained from the Muş Alparslan University Scientific Research and Publication Ethics Committee. Institutional permission was obtained from Atatürk University Research Hospital in order to carry out the study. Patients were informed about the purpose and method of the study and that the research was based on volunteerism in detail. Consent was taken from the patients participating in the study. The individuals participating in the research were informed that their data would not be shared.

RESULTS

Of the patients, 52% were female; 47.1% were aged between 51-70; 49% were primary school graduates; 69.5% had social security; 30.9% had a history of 1-2 wk-hospitalization; the sleep quality of 31.8% was between 7 and 8 (Table 1).

Validity findings

EFA: Reliability analysis was performed to determine whether the items had appropriate values. Therefore, 11 items were removed before starting the EFA. EFA was performed to ensure construct validity. In order to determine the items to be included in the scale, it was taken into account that there was no overlapping item, the item eigenvalue was 1, and the item load value was at least 0.30. The Cronbach alpha value of the remaining 31 items was determined to be 0.783. The analysis was continued with 31 items. Varimax axis rotation, a vertical rotation method preferred in scale development studies, was used in order to ensure construct validity.

Before performing exploratory and CFA for the scale, KMO and Bartlett's sphericity tests were performed to check the suitability of the sample size and the suitability of the data set for analysis. In addition, the anti-image test, which is one of the sampling criteria, was applied. The KMO value was determined as 0.663. Bartlett's sphericity test was found to be significant ($\chi^2 = 3019.015$; $P = 0.001$) (Table 2). As a result of the anti-image test, it was determined that there was no value below 0.50. These results showed that the sample size and data set were suitable for analysis.

Items i4, i5, i6, i13, i18, i19, i20, i23, i24, i28, i30, i39, and i40 were excluded from the scale since they were overlapping items. In the EFA performed with 18 items, it was determined that the KMO value was 0.741 and that Bartlett's sphericity test was significant ($\chi^2 = 1704.892$, $P = 0.001$). The anti-image test was examined and it was found that there was no value below 0.50. These findings showed that the data were suitable for factor analysis. As a result of the Varimax analysis, it was determined that the scale items were gathered under 5 factors. The scree plot also confirmed that the scale has a 5-factor structure. In light of this information, CFA was performed with 5 factors and 18 items (Figure 1).

When the analysis results were examined, it was found that factor 1 consists of 5 items, i22, i26, i29, i31, i32, and explained 22.345% of the total variance. This factor was named physical environmental factors.

Factor 2 consists of 4 items, i7, i14, i15, i16, and explained 18% of the total variance. This factor was named psychological factors.

Factor 3 consists of 3 items, i41, i42, i43, and explained 11.016% of the total variance. This factor was named safety factor.

Factor 4 consists of 3 items, i10, i11, i12, and explained 8.580% of the total variance. This factor was named socioeconomic factors.

Factor 5 consists of 3 items, i1, i2, i3, and explained 5.788% of the total variance. This factor was named nutritional factors.

When the 18-item scale was analyzed as a whole, it was determined that it has a 5-factor structure and that the common factor loads of 18 items varied between 0.407 and 0.886. It was determined that 5 factors explained 66.25% of the total variance. These values showed that the scale is sufficient to explain the hospital-acquired insomnia problems of patients (Table 3).

CFA: The structure obtained from EFA was tested with CFA. In line with the modification recommendations made with CFA, it was deemed appropriate to make modifications between items i10-i12 and i22-i29. After modification, improvements were observed in the χ^2 value. Information on the fit indices obtained as a result of CFA is given in the table. Fit values were evaluated considering the reference values stated (Table 4). The items were considered important for the factors in which they were included. The path diagram was examined and it was determined that the obtained values were appropriate in terms of the item-factor agreement (Figure 2).

Reliability findings

Internal consistency (Cronbach alpha) coefficients: The Cronbach alpha coefficient was calculated to

Table 1 Distribution of patients by sociodemographic characteristics (*n* = 221)

Characteristics	Variables	<i>n</i>	%
Sex	Famale	116	52
	Male	107	48
Age	18-30	16	7.2
	31-50	50	22.4
	51-70	105	47.1
	71 and above	52	23.3
Educational status	Illiterate	45	20.2
	Primary school	110	49.3
	Middle school	20	9
	High school and above	48	21.5
Social security	Yes	155	69.5
	No	68	30.5
Hospitalization	No	44	19.7
	Less than 1 wk	57	25.6
	1-2 wk	69	30.9
	2-3 wk	23	10.3
	1 mo and more	15	13.4
Sleep quality with 1 lowest 10 highest	1-2	21	9.4
	3-4	38	17.1
	5-6	49	22
	7-8	71	31.8
	9-10	44	19.8

Table 2 Cronbach's alpha, Kaiser-Meyer-Olkin values and Bartlett's test results for data sets

Tests	Test results	
Kaiser-Meyer-Olkin sampling adequacy	0.663	
Bartlett's test of sphericity	χ^2	3019.015
	Standard error	465
	<i>P</i> value	0.001

determine the reliability analysis of the 18 items of the finalized scale. The Cronbach alpha values were 0.672 for the nutritional factors subscale including items i1, i2, and i3; 0.677 for the socioeconomic factors including items i10, i11, i12; 0.804 for the psychological factors subscale including items i7, i14, i15, and i16; 0.842 for the physical environmental factors subscale including items i22, i26, i29, i31, i32; 0.786 for the safety factors subscale including i41, i42, and i43. The Cronbach alpha value for the overall scale was 0.783. These values show that the scale is reliable.

Split half confidence coefficient: As a result of the split half reliability analyses of the 18-item final version of the scale, it can be said that the Spearman-Brown correlation value ($r = 0.670$) and the Guttman split half coefficient value ($r = 0.60$) of the scale have sufficient values and that the Cronbach alpha reliability coefficients for the split halves are sufficient. The split half reliability coefficients are given in the table (Table 5). The results of the split half reliability analyses showed that the scale is reliable (Table 5).

The item score means were determined to be 1.06 ± 0.32 for F1, 1.57 ± 0.90 for F2, 1.12 ± 0.46 for F3, 1.41 ± 0.77 for F4, and 1.08 ± 0.27 for F5. The item score mean of HAIS was 1.25 ± 0.35 . The mean total ISI score was determined to be 10.35 ± 7.76 (Table 6).

Table 3 Hospital-acquired insomnia scale exploratory factor analysis results

	Common load value	Faktors				
		1	2	3	4	5
i31	0.781	0.869				
i26	0.758	0.865				
i32	0.713	0.843				
i22	0.567	0.733				
i29	0.554	0.729				
i16	0.781		0.855			
i15	0.727		0.815			
i14	0.662		0.666	0.339		
i7	0.485		0.647			
i41	0.886			0.924		
i42	0.758			0.835		
i43	0.572			0.696		
i11	0.704				0.783	
i12	0.552				0.705	
i10	0.666		0.392		0.680	
i3	0.747					0.855
i2	0.604					0.774
i1	0.407					0.631
Eigenvalue (total = 11.925)		4.022	3.334	1.983	1.544	1.042
% Total explained variance = 66.250%		22.345	18.521	11.016	8.580	5.788

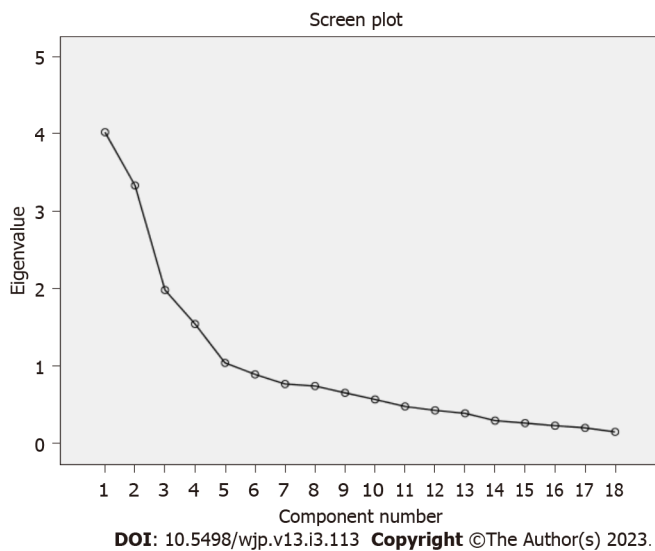

Figure 1 Scree plot factor structure.

It was determined that there was a positive and significant correlation between the mean ISI score and the mean scores on F2, F3, F4, and HAIS. A statistically significant correlation was found between HAIS and F1, F2, F3, F4, and F5. These findings show that the scale is an adequate tool to measure the hospital-acquired insomnia levels of patients (Table 7).

Table 4 Confirmatory factor analysis goodness of fit indices and normal values

Index	Normal value	Acceptable value	Measurement	Result
χ^2/P Value	> 0.05	-	0.001	Perfect fit
χ^2/SD (CMIN/DF)	< 2	< 5	1.874	Perfect fit
GFI	> 0.95	> 0.90	0.900	Acceptable fit
AGFI	> 0.95	> 0.85	0.861	Acceptable fit
CFI	>0.95	> 0.90	0.933	Acceptable fit
RMSEA	< 0.05	< 0.08	0.0.070	Acceptable fit
RMR	< 0.05	< 0.08	0.039	Perfect fit
SRMR	< 0.05	< 0.08	0.0600	Acceptable fit
NFI	> 0.95	> 0.80	0.869	Acceptable fit
TLI	0.95 < TLI < 1	0.90 < TLI < 0.94	0.917	Acceptable fit
IFI	> 0.90	-	0.934	Perfect fit
PGFI	> 0.89	> 0.50	0.648	Acceptable fit
PNFI	> 0.89	> 0.50	0.699	Acceptable fit

CMIN/DF: Chi-square fit statistic/degree of freedom; GFI: Goodness of fit index; AGFI: Adjusted goodness of fit index; CFI: Comparative fit index; RMSEA: Root mean square error of approximation; RMR: Root mean square residual; SRMR: Standardized root mean square residual; NFI: Normed fit index; TLI: Tucker-Lewis index; IFI: Incremental fit index; PGFI: Parsimony goodness of fit index; PNFI: Parsimony normed fixed index.

Table 5 Results of two-half confidence analysis

Two half	Cronbach alpha
Part 1	0.738
Part 2	0.606

Table 6 Mean score of the hospital-acquired insomnia scale and its sub-dimensions

	Average	SD	Min	Max
F1	1.06	0.32	1.00	5.00
F2	1.57	0.90	1.00	5.00
F3	1.12	0.46	1.00	4.00
F4	1.41	0.77	1.00	5.00
F5	1.08	0.27	1.00	3.00
Total hospital-acquired insomnia scale	1.25	0.35	1.00	3.06
Insomnia severity index	10.35	7.76	0	28

DISCUSSION

In order to create the conceptual structure of the scale and prepare the item pool, the literature was reviewed and in-depth interviews were conducted with 2 patients, 2 patient relatives, and 4 nurses. An item pool of 150 items was created. The item pool was reviewed 4 times and an item pool of 66 items was created to be presented to experts. Two Turkish language experts and 9 field experts were consulted. In line with the recommendations of 11 experts, 11 items were removed from the item pool and the pilot application started with 56 items. During the pilot application stage, 64 patients were reached. In line with the data obtained from 64 patients, 14 items were excluded since the total correlation value was low and the main application stage was initiated with 42 items.

During the main application stage, 223 individuals were reached. Reliability analyses were performed in line with the data obtained from 223 individuals and 11 items with low item correlation values were

Table 7 Relationship between the hospital-acquired insomnia scale and its sub-dimensions and the insomnia severity index

	F1	F2	F3	F4	F5	HAIS
Insomnia severity index						
r	-0.079	0.378 ¹	0.226 ¹	0.208 ¹	-0.061	0.334 ¹
P value	0.242	0.000	0.001	0.002	0.361	0.000
Total hospital-acquired insomnia scale						
r	0.303 ¹	0.886 ¹	0.343 ¹	0.705 ¹	0.281 ¹	1.000
P value	0.000	0.000	0.000	0.000	0.000	-

¹Correlation is significant at the 0.01 level (2-tailed).

HAIS: Hospital-acquired insomnia scale.

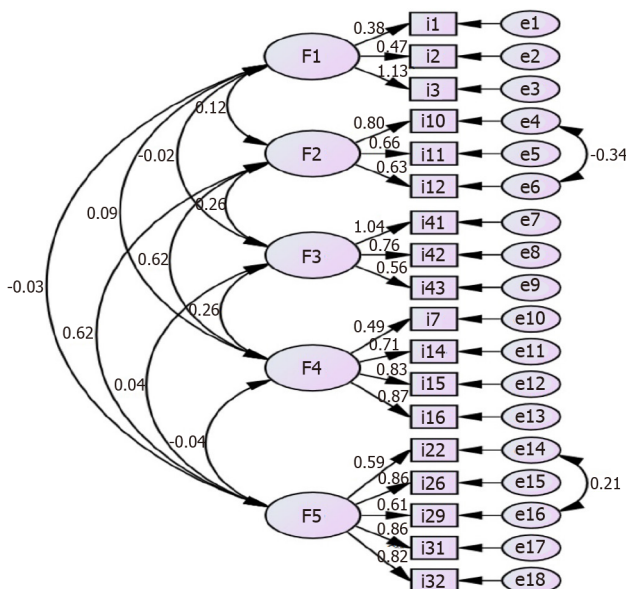

DOI: 10.5498/wjp.v13.i3.113 Copyright ©The Author(s) 2023.

Figure 2 Clinical application readiness scale confirmatory factor analysis diagram.

eliminated from the analysis. As a result of the EFA performed with 31 items, 13 items were excluded from the analysis one by one since they were overlapping. While each item was removed from the analysis one by one, KMO, Bartlett’s sphericity test, and anti-image test were checked. The overlapping status was checked and items were removed accordingly. Bartlett’s sphericity test, KMO value, and anti-image test were checked with the remaining 18 items. Bartlett’s sphericity test ($P < 0.05$), KMO value (0.741), and anti-image test for 18 items were found to be suitable for analysis[33-35]. As a result of the EFA of 18 items, a 5-factor structure was created. Scree plot also showed that the structure consisted of 5 factors. The items that constitute the factors were examined in terms of content integrity and named as physical environmental, psychological, safety, socioeconomic, and nutritional factors. CFA analysis of the 5-factor structure was performed in the AMOS package program. The fit indices of the obtained structure were examined. It was determined that the values obtained from the fit indices were sufficient. These results revealed that the scale is valid and reliable.

With the keywords “sleep” and “insomnia”, national and international literature was first searched on the Turkish measurement tools index and Google scholar. 20 relevant scales were reached. Eight scales were found to be regarding adult patients or associated with the hospital. The names of these scales were as follows; Pittsburgh sleep quality index[21], Epworth sleepiness scale[20], insomnia severity index[31], Richard-Campbell sleep questionnaire[23], DSM 5 sleep-wake disorders scale[22], Thought control questionnaire-insomnia revised[46], insomnia catastrophizing scale[47]. All scales were examined one by one and it was determined that there was no tool to determine hospital-acquired sleep problems. In addition, the subscales of the scales in question and the subscales of the hospital-acquired insomnia scale, which is the subject of the research, were examined and no similarity was detected. This shows the originality of the scale. It was determined that the Cronbach alpha values of the subscales ranged between 0.672 and 0.842 and the Cronbach alpha value for the overall scale was 0.783. It was

determined that the scale explained 58.269% of the total variance.

Practice implications

It is stated that patients who do not have sleep problems in their daily routine at home have problems after hospitalization, such as waking up frequently, having difficulty falling asleep, decreased sleep time, not feeling rested when they wake up, and inability to sleep. A new environment, the severity of the underlying disease, underlying psychiatric conditions, pain, room light, sharing a room with others, being away from the family, changes in sleep-wake-up times, pain, bad condition of the roommate patient, worrying about the disease, inadequate physical activity, frequent entries to the room, medications, and infections.

Hospital-acquired insomnia is usually treated symptomatically at the time of hospitalization. However, misuse or overuse of sedatives/hypnotics is thought to be associated with complications in this population of acute patients. The use of a scale to determine the causes and severity of insomnia before resorting to pharmacological methods is one of the indicators of quality nursing care. Prevention of hospital-acquired insomnia, which is evaluated with the scale, with simple and applicable nursing interventions will contribute to the prevention of unnecessary use of medications.

CONCLUSION

In conclusion, the scale consists of 18 items and 5 subscales: Physical environmental factors, psychological factors, safety factors, socioeconomic factors, and nutritional factors. The subscale of physical environmental factors consists of 5 items; psychological factors consist of 4 items; safety factors, socioeconomic factors, and nutritional factors subscales consist of 3 items. There is no reverse item on the scale. The item score average is used in the calculation of the scale score. The lowest score obtainable from the scale and 5 subscales is 1 and the highest score is 5. There is no cut-off point in the scale. As the scale score increases, the hospital-acquired insomnia level increases. The scale explains 66.250% of the total variance. In the light of this information, it can be said that the hospital-acquired insomnia scale is a valid and reliable measurement tool.

ARTICLE HIGHLIGHTS

Research background

Insomnia is a major problem for people. Many causes of insomnia have been reported. One of these reasons is hospital-acquired insomnia. Although it has been stated in many studies that patients experience hospital-acquired insomnia, it has been determined that there is no valid and reliable measurement tool that measures hospital-acquired insomnia problems of individuals.

Research motivation

Insomnia, which affects individuals physiologically, psychologically and therapeutically, is a serious problem in the hospital. Hospital-induced insomnia affects the quality of treatment and care. For this reason, healthcare professionals need a measurement tool that can measure the hospital-acquired insomnia levels of patients.

Research objectives

In this study, it was aimed to develop a valid and reliable measurement tool that can determine the hospital-acquired insomnia levels of patients.

Research methods

This research is scale development research consisting of a pilot application and a main application. First of all, an item pool was created for the scale and presented to expert opinion. After the expert opinion, the scale items were made ready for pre-application. In the preliminary application, data were obtained from 64 individuals. During the main application phase, 223 patients were reached. Exploratory factor analysis, confirmatory factor analysis and reliability analyzes were performed with the obtained data. Analyzes were performed using SPSS 20 package program and analysis of moment structure package program.

Research results

As a result of data analysis, it was determined that the scale consisted of 5 sub-dimensions and 18 items. The total Cronbach alpha value of the scale was determined to be 0.783.

Research conclusions

It was determined that the scale, which consists of 5 sub-dimensions and 18 items, is a valid and reliable measurement tool in determining the hospital-acquired insomnia levels of the patients.

Research perspectives

It is recommended to use this measurement tool to determine the insomnia problems of patients and to adapt it in other countries.

ACKNOWLEDGEMENTS

We thank the patients for taking part in the study.

FOOTNOTES

Author contributions: Çiftçi B contributed to the data collection; Yıldız GN contributed to the data analysis; Çiftçi B, Yıldız GN and Yıldız Ö wrote the manuscript and critically revised the important intellectual content; All authors contributed to the study design and study supervision.

Institutional review board statement: This work was approved by the Muş Alparslan University Scientific Research and Publication Ethics Committee, No. 16/08/2021-20028.

Informed consent statement: All study participants provided informed written consent prior to study enrollment.

Conflict-of-interest statement: The authors declared no potential conflicts of interest with respect to the research, authorship, and/or publication of this article.

STROBE statement: The manuscript was prepared and revised according to the STROBE statement.

Open-Access: This article is an open-access article that was selected by an in-house editor and fully peer-reviewed by external reviewers. It is distributed in accordance with the Creative Commons Attribution NonCommercial (CC BY-NC 4.0) license, which permits others to distribute, remix, adapt, build upon this work non-commercially, and license their derivative works on different terms, provided the original work is properly cited and the use is non-commercial. See: <https://creativecommons.org/licenses/by-nc/4.0/>

Country/Territory of origin: Turkey

ORCID number: Bahar Çiftçi 0000-0001-6221-3042; Güzel Nur Yıldız 0000-0003-1626-4089; Özgür Yıldız 0000-0002-1131-801X.

S-Editor: Zhang H

L-Editor: A

P-Editor: Zhang H

REFERENCES

- 1 **Demir D**, Yurdanur. Sleep and Sleep Related Applications. In: Akça Ay F. Basic Concepts and Skills in Health Practice. İstanbul: Nobel Medical Bookstore, 2016: 772-789
- 2 **Şevik Erdöl H**. Sleep. In: Akça Ay F. Basic Concepts and Skills in Health Practice. İstanbul: Academy Press and Publishing, 2019: 941-952
- 3 **Yahn H**, Kürtüncü M. Evaluation of Sleep and Rest. In: Eti Aslan F. Evaluation of Health. İstanbul: Academician Publishing House, 2014: 95-105
- 4 **Baker FC**, de Zambotti M, Colrain IM, Bei B. Sleep problems during the menopausal transition: prevalence, impact, and management challenges. *Nat Sci Sleep* 2018; **10**: 73-95 [PMID: 29445307 DOI: 10.2147/NSS.S125807]
- 5 **Solverson KJ**, Easton PA, Doig CJ. Assessment of sleep quality post-hospital discharge in survivors of critical illness. *Respir Med* 2016; **114**: 97-102 [PMID: 27109818 DOI: 10.1016/j.rmed.2016.03.009]
- 6 **Ho A**, Raja B, Waldhorn R, Baez V, Mohammed I. New onset of insomnia in hospitalized patients in general medical wards: incidence, causes, and resolution rate. *J Community Hosp Intern Med Perspect* 2017; **7**: 309-313 [PMID: 29147474 DOI: 10.1080/20009666.2017.1374108]
- 7 **Manian FA**, Manian CJ. Sleep quality in adult hospitalized patients with infection: an observational study. *Am J Med Sci* 2015; **349**: 56-60 [PMID: 25319438 DOI: 10.1097/MAJ.0000000000000355]
- 8 **Ho A**, Raja B, Baez Sosa V, Benno M, Waldhorn R. Acquired Insomnia in the Hospital, A Comprehensive Observational Study. *Am J Respir Crit Care Med* 2020; **201** [DOI: 10.1164/ajrccm-conference.2020.201.1]

- 9 **Badr AF**, Kurdi S, Alshehri S, McManus C, Lee J. Pharmacists' interventions to reduce sedative/hypnotic use for insomnia in hospitalized patients. *Saudi Pharm J* 2018; **26**: 1204-1207 [PMID: 30510473 DOI: 10.1016/j.jsps.2018.07.010]
- 10 **Lukoyanov AN**, Fomenko IS, Gongola MI, Shul'pina LS, Ikonnikov NS, Shul'pin GB, Ketkov SY, Fukin GK, Rummyantsev RV, Novikov AS, Nadolnny VA, Sokolov MN, Gushchin AL. Novel Oxidovanadium Complexes with Redox-Active R-Mian and R-Bian Ligands: Synthesis, Structure, Redox and Catalytic Properties. *Molecules* 2021; **26** [PMID: 34577177 DOI: 10.3390/molecules26185706]
- 11 **Tan X**, van Egmond L, Partinen M, Lange T, Benedict C. A narrative review of interventions for improving sleep and reducing circadian disruption in medical inpatients. *Sleep Med* 2019; **59**: 42-50 [PMID: 30415906 DOI: 10.1016/j.sleep.2018.08.007]
- 12 **Redberg RF**. JAMA Internal Medicine-The Year in Review, 2018. *JAMA Intern Med* 2019; **179**: 612-613 [PMID: 30907921 DOI: 10.1001/jamainternmed.2019.0508]
- 13 **Caddick J**, Green L, Stephenson J, Spyrou G. The psycho-social impact of facial skin cancers. *J Plast Reconstr Aesthet Surg* 2012; **65**: e257-e259 [PMID: 22440740 DOI: 10.1016/j.bjps.2012.02.022]
- 14 **Fındık Ü**, Topçu S. Effect of the Way of Surgery on Preoperative Anxiety. *J Hacettepe University Faculty Nurs* 2012; **19**: 22-33
- 15 **Elitoğ N**, Öztürk N, Menteş D, Zeytun B, Kahraman H, Kırdag G. Evaluation of Factors Affecting Sleep and Changes in Daily Sleep Patterns in Post-Op Hospitalization Periods of Patients Who Have Had Cardiac Surgery Operation. *Acibedem Nursing*. 2008; 1-4. Available from: http://www.acibademhemsirelik.com/edergi/yeni_tasarim/files/kalp%20bil_2.pdf
- 16 **Karagözoğlu Ş**, Çabuk S, Tahta Y, Temel F. Some factors influencing the sleep of hospitalized adult patients. *Thorax* 2007; **8**: 234-240 [DOI: 10.7475/kjan.2018.30.4.385]
- 17 **Uslu Y**, Korkmaz FD. Sleep in intensive care patients: nursing care. *J Educ Res Nurs* 2015; **12**: 156-161 [DOI: 10.5222/head.2015.156]
- 18 **Soong C**, Burry L, Greco M, Tannenbaum C. Advise non-pharmacological therapy as first line treatment for chronic insomnia. *BMJ* 2021; **372**: n680 [PMID: 33757960 DOI: 10.1136/bmj.n680]
- 19 **Stewart NH**, Arora VM. Sleep in Hospitalized Older Adults. *Sleep Med Clin* 2018; **13**: 127-135 [PMID: 29412979 DOI: 10.1016/j.jsmc.2017.09.012]
- 20 **Agargun M**, Cilli A, Kara H, Bilici M, Telcioglu M, Semiz U. The Validity and Reliability of the Epworth Sleepiness Scale. *Turk J Psychiatry* 1999; **10**: 261-267 [DOI: 10.1016/s1389-9457(09)70075-9]
- 21 **Ağargün MY**, Kara H, Anlar Ö. The validity and reliability of the Pittsburgh Sleep Quality Index. *Turk J Psychiatry* 1996; **7**: 107-115
- 22 **Yüzeren S**, Herdem A, Aydemir Ö. Reliability and validity of Turkish Form of Sleep Disorder Scale. *Anatol J Psychiatry* 2017; **18**: 79-84 [DOI: 10.5455/apd.241499]
- 23 **Özlu ZK**, Özer N. Richard-Campbell Sleep Scale Validity and Reliability Study. *J Turk Sleep Med* 2015; **2**: 29-32 [DOI: 10.4274/jtsm.02.008]
- 24 **Boz İ**, Selvi N. Testing the Psychometric Properties of the Postpartum Sleep Quality Scale in Turkish Women. *J Nurs Res* 2018; **26**: 385-392 [PMID: 29219941 DOI: 10.1097/jnr.0000000000000253]
- 25 **Önder İ**, Masal E, Demirhan E, Horzum MB, Beşoluk Ş. Psychometric properties of sleep quality scale and sleep variables questionnaire in Turkish student sample. *Int J Psychol Educ Stud* 2016; **3**: 9-21 [DOI: 10.17220/ijpes.2016.03.002]
- 26 **Duruöz MT**, Erdem D, Gencer K, Ulutatar F, Baklacioğlu HŞ. Validity and reliability of the Turkish version of the Jenkins Sleep Scale in psoriatic arthritis. *Rheumatol Int* 2018; **38**: 261-265 [PMID: 29250729 DOI: 10.1007/s00296-017-3911-2]
- 27 **Ozdemir PG**, Boysan M, Selvi Y, Yildirim A, Yilmaz E. Psychometric properties of the Turkish version of the Sleep Hygiene Index in clinical and non-clinical samples. *Compr Psychiatry* 2015; **59**: 135-140 [PMID: 25708650 DOI: 10.1016/j.comppsy.2015.02.001]
- 28 **Arıcıoğlu A**. Sleep Rating Scale for Children with Cancer: Adolescent Form. M.Sc. Thesis, Dokuz Eylül University. 2018. Available from: <https://tez.yok.gov.tr/UlusalTezMerkezi/tezSorguSonucYeni.jsp>
- 29 **Tosunoğlu A**. Investigation of factors affecting sleep needs of hospitalized adult patients. M.Sc. Thesis, İzmir: University; 1997. Available from: <https://tez.yok.gov.tr/UlusalTezMerkezi/tezSorguSonucYeni.jsp>
- 30 **Alpar R**. Applied statistics and validity reliability, with examples from sports health and educational sciences. 7th ed. Ankara: Detay Publishing; 2022: 1-672
- 31 **Bastien CH**, Vallières A, Morin CM. Validation of the Insomnia Severity Index as an outcome measure for insomnia research. *Sleep Med* 2001; **2**: 297-307 [PMID: 11438246 DOI: 10.1016/s1389-9457(00)00065-4]
- 32 **Boysan M**, Gulec M, Besiroglu L, Kalafat T. Psychometric properties of the Insomnia Severity Index in Turkish sample. *Anatol J Psychiatry* 2010; **11**: 248-252 [DOI: 10.5455/apd.42654]
- 33 **Tavşancıl E**. Measuring attitudes and data analysis with SPSS. Ankara: Nobel Publishing; 2018: 1-174
- 34 **Correction: Alagoz F**, Yildirim AE, Sahinoglu M, Korkmaz M, Secer M, Celik H, Yel C, Guvenc Y, Uckun OM, Narin F, Daglioglu E, Belen AD. Traumatic Acute Subdural Hematomas: Analysis of Outcomes and Predictive Factors at a Single Center. *Turk Neurosurg* 2017; **27**(2):187-191. *Turk Neurosurg* 2017; **27**: 487 [PMID: 28452392 DOI: 10.5137/1019-5149.JTN.20651-17.0]
- 35 **Esin MN**. Data collection methods and tools-reliability and validity of data collection tools. In: Erdoğan S, Nahcivan N, Esin MN. Research, process practice and critical in nursing. İstanbul: Nobel Medical Bookstores; 2021: 193-235
- 36 **DeVellis RF**, Thorpe CT. Scale development: Theory and applications. Los Angeles: Sage publications; 2021: 1-103
- 37 **Pallant J**. SPSS user manual: Step-by-step data analysis with SPSS. 3th ed. New York: McGraw Hill Hause; 2020: 1-211
- 38 **Aksu G**, Eser MT, Güzeller CO. Exploratory and Confirmatory Factor Analysis and Structural Equation Model Applications. Ankara: Detail publishing; 2017: 1-247
- 39 **Ho RC**, Hou Hong Ng A, Nourallah M. Impact of Globalization and Advanced Technologies on Online Business Models. IGI Global; 2021. 1-321
- 40 **Kim C**. Misuse of exploratory factor analysis and its remedies. *Survey Res* 2016; **17**: 1-29
- 41 **Bae BR**. Structural equation modeling with Amos 24. Seoul: Chenngram Books; 2017: 76-309

- 42 **Woo JP.** The concept and understanding of structural equation model. Seoul: Hannarae, 2017: 230-236
- 43 **Kyriazos TA, Stalikas A.** Applied psychometrics: The steps of scale development and standardization process. *Psychol* 2018; **9**: 2531 [DOI: [10.4236/psych.2018.911145](https://doi.org/10.4236/psych.2018.911145)]
- 44 **Noh G.** The proper methods of statistical analysis for dissertation: SPSS & AMOS 21. Seoul: Hanbit Academy; 2019
- 45 **Taber KS.** The use of Cronbach's alpha when developing and reporting research instruments in science education. *Res Sci Educ* 2018; **48**: 1273-1296 [DOI: [10.1007/s11165-016-9602-2](https://doi.org/10.1007/s11165-016-9602-2)]
- 46 **Yıldırım A, Boysan M, Aktaş SA.** Validation of the Turkish version of the Thought Control Questionnaire-Insomnia Revised (TCQI-R). *Yeni Symposium* 2018; 9-16 [DOI: [10.5455/nys.20190111123743](https://doi.org/10.5455/nys.20190111123743)]
- 47 **Uygur ÖF, Hursitoğlu O, Uygur H, Aydın EF, Orhan FÖ.** Turkish adaptation of the Insomnia Catastrophizing Scale and its psychometric properties. *J Clin Psy* 2022; **25**: 101-111 [DOI: [10.5505/kpd.2022.54189](https://doi.org/10.5505/kpd.2022.54189)]